

2025H

Diesel
Pneumatic Tire Forklifts



| Model | Capacity @ 500mm LC | Fuel Type | Engine |
|-------|---------------------|-----------------|-------------------------|
| 2025H | 2,500 kg | Diesel | XinchaiA490BPG/2.54L |
| 2025H | 2,500 kg | Diesel Tier III | Yanmar4TNE92-HRJ/2.659L |



2025H

Diesel • Pneumatic Tire Forklifts



| General | 1 | Model | | | 2025H | 2025H |
|-------------|-------------|--------------------------|-------------------------------|----------|----------------|-------------------|
| | | 2 | Power Type | | | Diesel |
| | 3 | Base Capacity | @ rated load center | kg | 2,500 | 2,500 |
| | 4 | Load Center | | mm | 500 | 500 |
| Weights | 5 | Service Weight | unloaded | kg | 3,800 | 3,800 |
| | 6 | Axle Load | loaded/unloaded, front | kg | 5,545 / 1,520 | 5,545 / 1,520 |
| | 7 | | loaded/unloaded, rear | kg | 755/2,280 | 755/2,280 |
| Tires | 8 | Tire Type | | | Pneumatic | Pneumatic |
| | 9 | Wheels | front/rear | | 2/2 | 2/2 |
| | 10 | Wheelbase | | mm | 1,600 | 1,600 |
| | 11 | Tire Size | front | | 7.00-12-12PR | 7.00-12-12PR |
| | 12 | | rear | | 6.00-9-10PR | 6.00-9-10PR |
| 13 | Tread Width | front/rear | | 970 /980 | 970 /980 | |
| Mast | 14 | Max. Fork Height | with std 2-stage mast | mm | 3,000 | 3,000 |
| | 15 | Freelift | with std 2-stage mast | mm | 150 | 150 |
| | 16 | Height, Upright Lowered | with std 2-stage mast | mm | 2,030 | 2,030 |
| | 17 | Height, Upright Extended | with std 2-stage mast | mm | 4,045 | 4,045 |
| | 18 | Mast Tilt, Fwd/Back | with std 2-stage mast | deg | 6° / 12° | 6° / 12° |
| | 19 | Carriage | width | mm | 1,100 | 1,100 |
| | 20 | Fork Spread | minimum/maximum | mm | 244/ 1,032 | 244/ 1,032 |
| | 21 | Fork Dimensions | T x W x L | mm | 40 x 122 x 920 | 40 x 122 x 920 |
| Chassis | 22 | Length to Fork Face | with std 2-stage mast | mm | 2,560 | 2,560 |
| | 23 | Overall Width | | mm | 1,150 | 1,150 |
| | 24 | Overhead Guard Height | | mm | 2,170 | 2,170 |
| | 25 | Turning Radius | minimum outside | mm | 2,280 | 2,280 |
| | 26 | Fork Overhang | with std 2-stage mast | mm | 464 | 464 |
| | 27 | Right Angle Stack | add load length and clearance | mm | 3,840 | 3,840 |
| | 28 | Ground Clearance | minimum loaded | mm | 135 | 135 |
| | 29 | | center of wheelbase | mm | 145 | 145 |
| Performance | 30 | Travel Speed | loaded/unloaded | km/h | 20 / 21 | 20 / 21 |
| | 31 | Lift Speed | loaded/unloaded | m/s | 0.45 /0.52 | 0.45 /0.52 |
| | 32 | Lower Speed | loaded/unloaded | m/s | 0.48 /0.45 | 0.48 /0.45 |
| | 33 | Max. Drawbar Pull | loaded | kg | 2,225 | 2,225 |
| | 34 | Max. Gradeability | loaded/unloaded | % | 18/20 | 18/20 |
| Systems | 35 | Brakes | service | | Foot / Hyd | Foot / Hyd |
| | 36 | | parking | | Hand / Mech | Hand / Mech |
| | 37 | Engine | manufacturer | | Xinchai | Yanmar |
| | 38 | | model | | A490BPG | 4TNE92-HRJ |
| | 39 | | emission compliance | | China Tier II | EPA/Euro Tier III |
| | 40 | | cylinders | | 4 | 4 |
| | 41 | | displacement | liter | 2.54 | 2.659 |
| | 42 | | rated power | kw/rpm | 36.8/2,650 | 32.8/2,450 |
| | 43 | | max. torque | N-m/rpm | 148/1,900 | 140/1,700 |

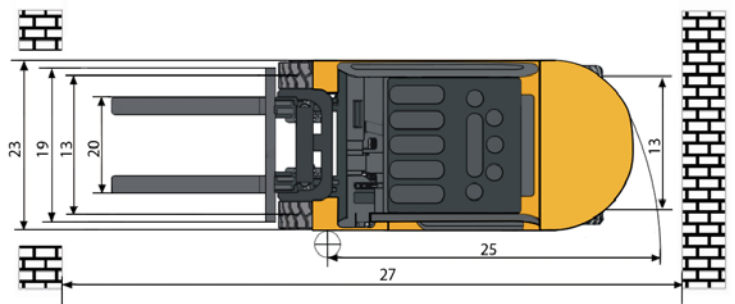
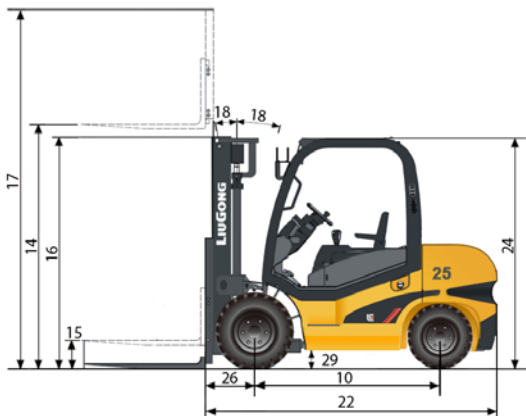

Specifications and designs are subject to change without notice. Machines shown may include optional equipment.

Guangxi Liugong Machinery Co., Ltd.
 No. 1 Liutai Road, Liuzhou, Guangxi 545007, PR China
 T: +86 772 3886124 E: overseas@liugong.com
 www.liugong.com

02/2013 Designed by Liugong