

# TPWN09 "NETWORK" SERIES PALLET TRUCK SCALE

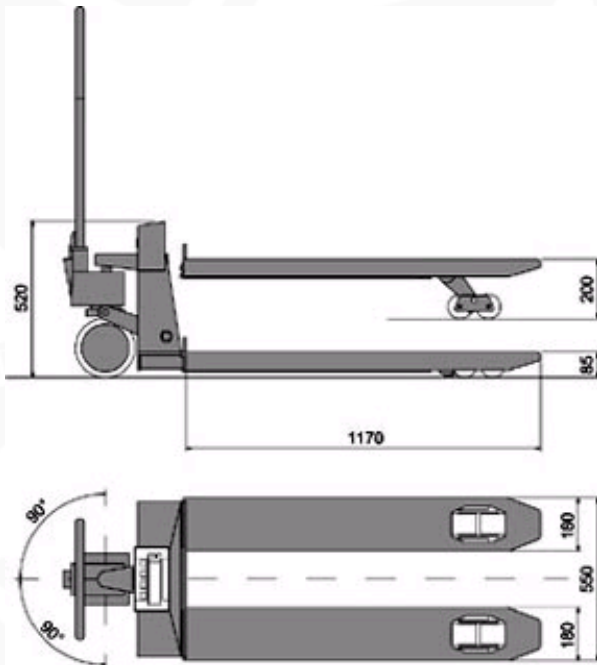

TPWN09



Dimensions in mm

Easy to use and handy pallet trucks with integrated electronic weighing. It is fitted with 4 shear-beam load cells, that guarantee the maximum precision in the weighing applications, and a multifunctional weight indicator, with large backlit display that allows an optimal reading of the weight in any lighting condition.

Available also with the remote control on the handle-bar and in TRIPLE RANGE model.

## MAIN FEATURES

- Maximum lifting capacity: 2000 kg.
- Accuracy: +/- 0.5% of the capacity on single-range version.
- Accuracy: +/- 0.1% of the capacity on multi-range version.
- Fork dimensions: 1170 x 550 x 85 mm.
- Weighs about 125 kg.
- Structure in extra thick steel and oven-fire painted mechanics.
- Steering wheels and double loading rollers with a polyurethane coating.
- 4 aluminium shear-beam load cells.
- Weight indicator with **6 25mm digits on a backlit LCD display**, which are clearly visible even in poor lighting conditions, and waterproof keyboard, with 5 functional keys.
- **Configuration, calibration and diagnostics from keyboard or PC with DINITOOLS.**
- Power supply through 4 AA batteries, which may also be rechargeable.
- The operating time is of about 40 hours of continuous use, or one month with the typical non continuous use, thanks to its auto switch-off function.
- Programmable auto power saving function.
- Battery level indication.
- IP input for managing the remote control.

## SELECTABLE FUNCTIONS

- **High Resolution Weighing x 10**
- **Net/Gross or lb/kg conversion**
- **Totalization**
- **Formula weighing**
- **+/- checkweighing**
- **Percentage weighing**
- **Counting**

## KEYBOARD FUNCTIONS

- Zeroing, semi automatic tare, manual tare, activation of the selected function, print, ON/OFF.

## I/O SECTION

- Infra-red port for remote control on handle-bar (the remote control is optional).

## OPTIONS TO BE SPECIFIED WHEN ORDERING

- Parking brake.
- Remote control handle-bar.
- Special wheels available with price estimate.

## Available versions

Code	Max Capacity kg	Division kg
TPWN09	2000	1
TPWN093R	500 / 1000 / 2000	0,5 / 1 / 2

Options only available at time of order

**Code** **Description**

DFTL Remote control for use up to 8m, configurable as a single tare key or four keys

TPWFRE Parking brake system with command pedal mounted on steering wheels

**Accessories****Code** **Description**

TECMAN Printed technical manual (free, if downloaded from the web) NET PRICE

UMAN Printed user manual (free, if downloaded from the web) NET PRICE

Dini Argeo S.r.l.

Copyright - All Rights Reserved -

www.diniargeo.com

[Privacy Policy](#)